



J/70 South American Championship 2022

December 3 to 9, 2022

Veleiros do Sul, Porto Alegre, RS, Brazil

The Organizing Authority (OA) is the Veleiros do Sul Associação Náutica Desportiva and the International J/70 Class Association (IJ70CA).

Veleiros do Sul Associação Náutica Desportiva is located at Av. Guaíba, 2941, Porto Alegre, RS Brazil

Phone: +55 51 3265.1717 | Event Website: [www.vds.com.br/j70]

Event Chair: esportiva@vds.com.br | See SI 24 for full contact information

Sailing Instructions

The notation [DP] in a rule of these Sailing Instructions (SIs) means that the penalty for a breach of that rule may, at the discretion of the jury, be less than disqualification. See SI 12.7 and 12.8 for details. This changes RRS 64.2. The notation [NP] in a rule of the Sailing Instructions means that a boat may not protest another boat for breaking that rule. This changes RRS 60.1(a).

1. CHANGES TO SAILING INSTRUCTIONS

- 1.1 Any change to the SIs will be posted before 1000 on the day it will take effect, except that any change to the schedule of races will be posted by 1900 on the day before it will take effect.

2. COMMUNICATION

- 2.1 Notices to competitors will be posted on the Official Notice Board near the Race Office in front of the restaurant of Veleiros do Sul with the time of publication stated on the document. Notices will also be posted on the “J/70 South American” WhatsApp group (**Attachment E** contains the QR code to join that group) as a courtesy, to facilitate de communication.
- 2.2 Any questions regarding the SIs shall be submitted in writing to the Race Committee (RC). The questions and any answers will be posted as in SI 2.1.
- 2.3 A competitors’ briefing will be held on December 6 at 1000 at the club’s restaurant.

- 2.4 On the water, the RC intends to monitor and communicate with competitors on VHF radio channel 68 ('the VHF Channel'). Failure of the RC to broadcast, mistaken broadcasts, or failure of a competitor to receive this information will not be grounds for a request for redress. This changes RRS 60.1(b).
- 2.5 Except as provided in SI 2.6, a boat shall not make voice or data transmissions while racing and shall not receive voice or data communication that is not available to all boats. [DP]
- 2.6 Boats shall use the radio to report retirement from racing and may use the radio to request or provide assistance in an emergency. [NP] [DP]

3. SIGNALS MADE ASHORE

- 3.1 Signals made ashore will be displayed on the flagpole located near at the Race Office in front of restaurant.
- 3.2 When flag AP is displayed ashore, "1 minute" is replaced with "not less than sixty (60) minutes" in The Racing Rules of Sailing (RRS) Race Signal AP.

4. SCHEDULE AND FORMAT OF RACES

4.1 Race Schedule

Day week	Day	Time	Activity
Saturday	December 03	0900 – 1800 0900 – 1800	Check-in and inspection Registration Open
Sunday	December 04	0900 – 1800 0900 – 1800	Check-in and inspection Registration Open
Monday	December 5	0900 – 1800 1100 1300 1800	Check-in and inspection Opening Ceremony Warning Signal for Practice Race Check-in closes; all boats, sails, and equipment must be inspected and boats must be afloat. [DP]
Tuesday	December 6	1000 1300 After Racing	Competitors' Briefing First warning signal - subsequent race(s) to start ASAP Daily Awards & Social Event
Wednesday	December 7	1300 After Racing	First warning signal - subsequent race(s) to start ASAP Daily Awards & Social Event
Thursday	December 8	1300 After racing	First warning signal - subsequent race(s) to start ASAP Daily Awards & Social Event
Friday	December 9	1300 1630 1900	First warning signal - subsequent race(s) to start ASAP No warning signal shall be given after 1630 Awards ceremony
Saturday	December 10	TBD	Haul out / de-rig

- 4.2 Up to twelve (12) races are scheduled with three (3) races per day on Tuesday through Friday, December 06 - 09. A maximum of three (3) races may be sailed in one day. Up to four (4) races may be sailed in one day if needed to complete the scheduled number of races. The RC, at its discretion, may run fewer total races.

- 4.3 The scheduled time of the first warning signal each day is 1300. Subsequent races will start as soon as practicable.
- 4.4 On Friday, December 09, no warning signal will be made after 1630 local time. In the case of one or more general recall(s) when the initial warning signal was made prior to 1630, the RC may display subsequent warning signals after that time. This exception will not apply for a race that is postponed or abandoned.
- 4.5 All boats shall sail as one fleet.

5. CLASS FLAG

The class flag is a blue J/70 logo on a white background.

6. RACING AREA

Attachment A shows the location of the racing area.

7. MARKS

- 7.1 Marks 1, 1A (offset), 2S /2P (gate), are yellow pyramidal inflatable buoys
- 7.2 New marks, as provided in SI 10, are orange pyramidal inflatable buoys
- 7.3 Starting marks are RC vessel and white with black stripe inflatable buoy.
- 7.4 Finish marks are RC vessel and white with black stripe inflatable buoy.

8. COURSES

- 8.1 The course to be sailed will be a windward-leeward format. The diagrams in **Attachment B** show the course, including the order in which marks are to be passed, and the side on which each mark is to be left.
- 8.2 No later than the warning signal for each race, the RC signal vessel will use placards to identify the approximate magnetic bearing and distance to the first weather mark.

9. THE START

- 9.1 The starting line is between staff displaying orange flag on the starboard RC signal vessel and an inflatable mark.
- 9.2 To alert boats that a race will begin soon, orange starting line flag will be displayed with one long sound signal on the RC signal vessel marking the line for a minimum of 5 minutes before the warning signal is displayed.
- 9.3 Boats subject to individual recall under RRS 29.1 or boats breaking RRS 30.3 (*U Flag Rule*) or RRS 30.4 (*Black Flag Rule*) may be broadcast on the VHF Channel using bow numbers or sail numbers as a courtesy. Failure to broadcast or hear the broadcasts shall not be grounds for granting redress.
- 9.4 In the event of a General Recall or abandonment after the start during a RRS 30.4 (*Black Flag Rule*) start, the RC shall broadcast on the VHF Channel and display the bow number or sail number of any boat violating RRS 30.4 before the next warning signal. This changes RRS 30.4.
- 9.5 The RC will attempt to make the broadcasts described in SI 9.3 and 9.4. However, the timing of such a broadcast, the sequence of the broadcasts or the failure to make or hear the broadcasts shall not be grounds for granting redress. This changes RRS 62.1(a).
- 9.6 A boat that does not start within five (5) minutes after her starting signal will be scored Did Not Start (DNS) without a hearing. This change is added to RRS A5.1.

10. CHANGING THE NEXT LEG OF THE COURSE

To change the next leg of the course, the RC will lay a new mark (or move the finishing line) and remove the original mark as soon as practicable. When in a subsequent change a new mark is replaced, it will be replaced with the original mark.

11. THE FINISH

The finish line is between staff displaying blue flag on RC vessel and white with black stripe inflatable buoy.

12. PENALTY SYSTEM

- 12.1 The first sentence of RRS 44.1 is changed to “A boat may take a One-Turn Penalty when she may have broken one or more rules of Part 2 in an incident while racing, except that when she may have broken a rule of Part 2 while in the **zone** around a mark other than a starting mark, her penalty shall be a Two-Turns Penalty.”
- 12.2 Penalties incurred while in the **zone** of the windward mark or on the offset leg shall be delayed and taken at the first reasonable opportunity on the downwind leg. This change is added to RRS 44.2.
- 12.3 RRS Appendix P (Special Procedures for Rule 42) is in effect and replaced in its entirety as stated in **Attachment C**.
- 12.4 Jury vessels may be positioned anywhere on the course area. Their position at any time will not be grounds for a request for redress. This changes RRS 60.1(b).
- 12.5 A boat that has taken a penalty under RRS 31 or RRS 44.1 shall submit a completed penalty acceptance form at the jury desk or regatta website within the protest time limit.
- 12.6 Not used.
- 12.7 The IJ may impose discretionary penalties other than disqualification for violations of RRS non-Part 2 rules. This section 12.7 does not apply to breaches of RRS 2, 28 or 31.
- 12.8 The IJ may impose discretionary penalties other than disqualification for violations of Notice of Race, SI, Class Rules, including the International J/70 Class Rules (J70CR) and the J/70 Equipment Regulations (J70ER). However, in no case shall the penalty for such a violation be less than a ten percent (10%) scoring penalty calculated pursuant to RRS 44.3(c). This changes RRS 64.6.

13. TIME LIMITS AND TARGET TIMES

- 13.1 The race time limit for each race is 75 minutes. The target time for each race is 45-50 minutes. Failure to meet the target time will not be grounds for a request for redress. This changes RRS 60.1(b).
- 13.2 Boats failing to finish within 20 minutes after the first boat sails the course and finishes within the race time limit will be scored Time Limit Expired (TLE) without a hearing, unless they subsequently retire, are penalized or are given redress. The score for TLE is the number of finishers plus two points, but no worse than the score for DNF. This changes RRS 35 and is added to RRS A4 and A5.
- 13.3 The RC will lower the finish line flag with one sound to indicate that the time limit has expired.

14. HEARING REQUESTS

- 14.1 The jury desk will be located at the lobby of race office. The hearing room will be located at Conselho Deliberativo room.
- 14.2 The protest period will be 75 minutes after the finish of the last boat in the last race of the day or after the race committee signals that there will be no more races today, whichever is later. This time will be posted on the Official Notice Board and Whats App Notice Board as a courtesy.
- 14.3 The second sentence of RRS 62.2 is replaced with: “If the request is based on an incident in the racing area, it shall be filed within the protest time limit for that day.”
- 14.4 A notice of boats scored per RRS A5.1 and SI Attachment C each day will be posted on the Official Notice Board and at the jury desk no later than the protest time limit. The deadline for a request for redress based on these scores is the protest time limit for that day. This changes RRS 62.2.
- 14.5 The time limit for a request for redress based on the outcome of a scoring inquiry (see SI 15.4) is 30 minutes after that outcome has been posted. This changes RRS 62.2.

- 14.6 The J70 Class Rule C3.2 (a) & (b) and Categorization Protest Time Limit is the Protest Time Limit on the Practice Race Day on December 5th.
- 14.7 Hearing request forms are available at the jury desk or on the regatta office.
- 14.8 Penalty acceptance forms are available at the jury desk or on the regatta office.
- 14.9 Notices will be posted no later than fifteen (15) minutes after the protest time limit each day on the Official Notice Board and inform competitors of hearings in which they are parties or named as witnesses. Hearings will be heard as soon as possible.
- 14.10 On the last day of the event, a request for reopening a hearing shall be delivered within the protest time limit if the requesting party was informed of the decision on the previous day or no later than 30 minutes after the requesting party was informed of the decision on that day. This changes RRS 66.2.
- 14.11 On the last day of the event, a request for redress based on a jury decision shall be delivered no later than 30 minutes after the decision was posted. This changes RRS 62.2.

15. SCORING

- 15.1 Scoring shall be according to the Low Point Scoring System of RRS A2 and A4 as follows:
 - (a) When fewer than five (5) races have been completed, a boat's series score shall be the total of her race scores;
 - (b) When five (5) or more races have been completed, a boat's series score shall be the total of her race scores excluding her worst score.
- 15.2 Four (4) Races race is required to constitute a championship.
- 15.3 Preliminary results will be posted on the event official notice board as soon as possible after racing each day.
- 15.4 Competitors shall notify the RC of any scoring inquiry by filing a Scoring Inquiry Form available at the race office. The deadline to file a scoring inquiry is the protest time limit or thirty (30) minutes after the preliminary results have been posted for that day, whichever is later.

16. SAFETY REGULATIONS [DP]

- 16.1 A boat that retires from a race or leaves the racing area between races shall notify the RC as soon as possible using the VHF Channel.
- 16.2 A boat not leaving the harbor for any of the day's racing shall inform the RC as soon as possible.
- 16.3 The penalty for breaking a rule in SI 16 shall be a twenty percent (20%) scoring penalty calculated pursuant to RRS 44.3(c) unless the Jury decides differently, applied without a hearing to a boat's first valid race of the day. This change is added to RRS A5.1.
- 16.4 Each boat is allowed to carry a jerry can with a capacity of up to 5 liters of fuel. If used or removed from the boat, a declaration to the Technical Committee is mandatory.

17. BOW NUMBERS [NP]

- 17.1 Bow numbers will be supplied and applied by the OA in accordance with the J70ER 6 and J70ER Appendix A as shown in **Attachment D**.
- 17.2 Bow numbers shall be displayed from the time they are applied by the OA through the end of the event. It is the responsibility of the competitor to ensure that the bow numbers remain on the boat and obtain replacements as necessary.

18. REPLACEMENT OF CREW OR EQUIPMENT [DP]

- 18.1 Substitution of competitors is not allowed without written approval of the event Technical Committee prior to racing on that day.

- 18.2 Repair, alteration, replacement, or substitution of damaged or lost equipment will not be allowed unless authorized before racing by the event Technical Committee pursuant to J70ER 10.
- 18.3 J/70 Equipment Regulation 4.3 will apply
- 18.4 Boats requesting approvals under SI 18.1 or SI 18.2 shall contact the event Technical Committee for instructions:
 - (a) If off the water: by phone, text message, or WhatsApp (see SI 24 for contact information);
 - (b) If on the water: hailing on the VHF Channel to the Race Committee. Race Committee will relay the request to the Technical Committee.

19. EQUIPMENT AND MEASUREMENT CHECKS [DP]

Pursuant to J70ER 4, a boat, sails or equipment may be inspected at any time for compliance with the Event Equipment Rules (see J70ER 2), IJ70CA Class Rules (J70CR), and SIs. On the water, when instructed by a member of the RC or event Technical Committee, a boat shall proceed immediately to a designated area for inspection.

20. EVENT ADVERTISING [NP] [DP]

- 20.1 Boats shall display any event advertising supplied by the OA, in accordance with World Sailing Regulation 20. If this rule is broken, World Sailing Regulation 20.9.2 applies.
- 20.2 Any required sponsor or event identification stickers, decals and flags shall be placed on the bow or boom, in the cockpit or on a shroud or stay as directed by the OA. They shall be displayed from the close of check-in through the end of the event. If required to be placed on the bow, they shall be placed immediately aft of the bow numbers. It is the responsibility of the competitor to ensure that the stickers remain on the boat and obtain replacements as necessary.

21. OFFICIAL VESSELS [NP]

Official vessels are marked as follows:

Category	Flag
RC Vessels	Yellow flag with black letter "RC"
Jury Vessels	Flag with letter "J"
Technical Committee (Measurer)	White flag with black "M"
Press Vessels	Pink flag with black "P"
Coach and Support Vessels	Number Stick

- 21.1 Only registered Support Person Vessels (SPVs), including coach, press, private and spectator vessels that prominently display identification provided by the OA are allowed in the racing area (see SI 6). The person in charge of the competing boat(s) to which support vessels are attached shall acknowledge the presence of a support vessel on his check-in form and may pay the applicable fee on behalf of the support vessel.
- 21.2 All SPVs shall carry a working VHF radio capable of transmitting and receiving normal domestic and international channels, including the VHF Channel.
- 21.3 SPVs, and team leaders, coaches, and other support personnel, shall stay more than 150 meters to leeward of the starting line, leeward marks, and from any competing boats that are racing.
- 21.4 SPVs shall comply with any additional directions given by the OA, the RC or the Jury, including requests for assistance with rescues. Failure to comply may result in the accreditation being withdrawn and all access to the club facilities, grounds and docks being denied.
- 21.5 SPVs shall be kept in the places, both afloat and ashore, that they specify during check-in.
- 21.6 Operators of SPVs and all competitors are reminded that J70CR I.3 (Outside Assistance) is in effect.

22. RESTRICTIONS ON BOAT LIFTING

22.1 [DP] The boats shall not be taken out of the water during the entire event, except with the permission of and on terms previously authorized in writing by the Event Technical Committee.

23. TRASH DISPOSAL [DP]

Trash shall be placed in the appropriate containers when the boats return to shore.

24. RISK STATEMENT

Competitors participate in the event entirely at their own risk. See RRS 3, Decision to Race. By participating in the event, each competitor agrees to release the race organizers (organizing authority, host yacht club, race committee, protest committee, sponsors, and any others acting in an official capacity for the event) from any and all liability associated with such competitor's participation in the event to the fullest extent permitted by law.

25. RACE OFFICIALS

Club Contact:

Veleiros do Sul

Av. Guaíba, 2941 – Porto Alegre, RS - Brasil

esportiva@vds.com.br | www.vds.com.br

Regatta Chair:

Kadu Bergenthal, kadubergenthal@hotmail.com

Veleiros do Sul Fleet Captain:

Marcos Pinto Ribeiro, marcos@rage.com.br

Principal Race Officer:

Odecio Carlos Adam (IRO) esportiva@vds.com.br

Jury Chairman:

Flavio Naveira (IJ) - ARG, naveirafavio@gmail.com

Event Technical Committee Chair/Head Measurer: Thomas Loesch, IM (Mobile/WhatsApp: +49 163 877 5400)

Measurer:

Manolo Bunge - +55 12 99791.4881

ATTACHMENT A RACING AREA

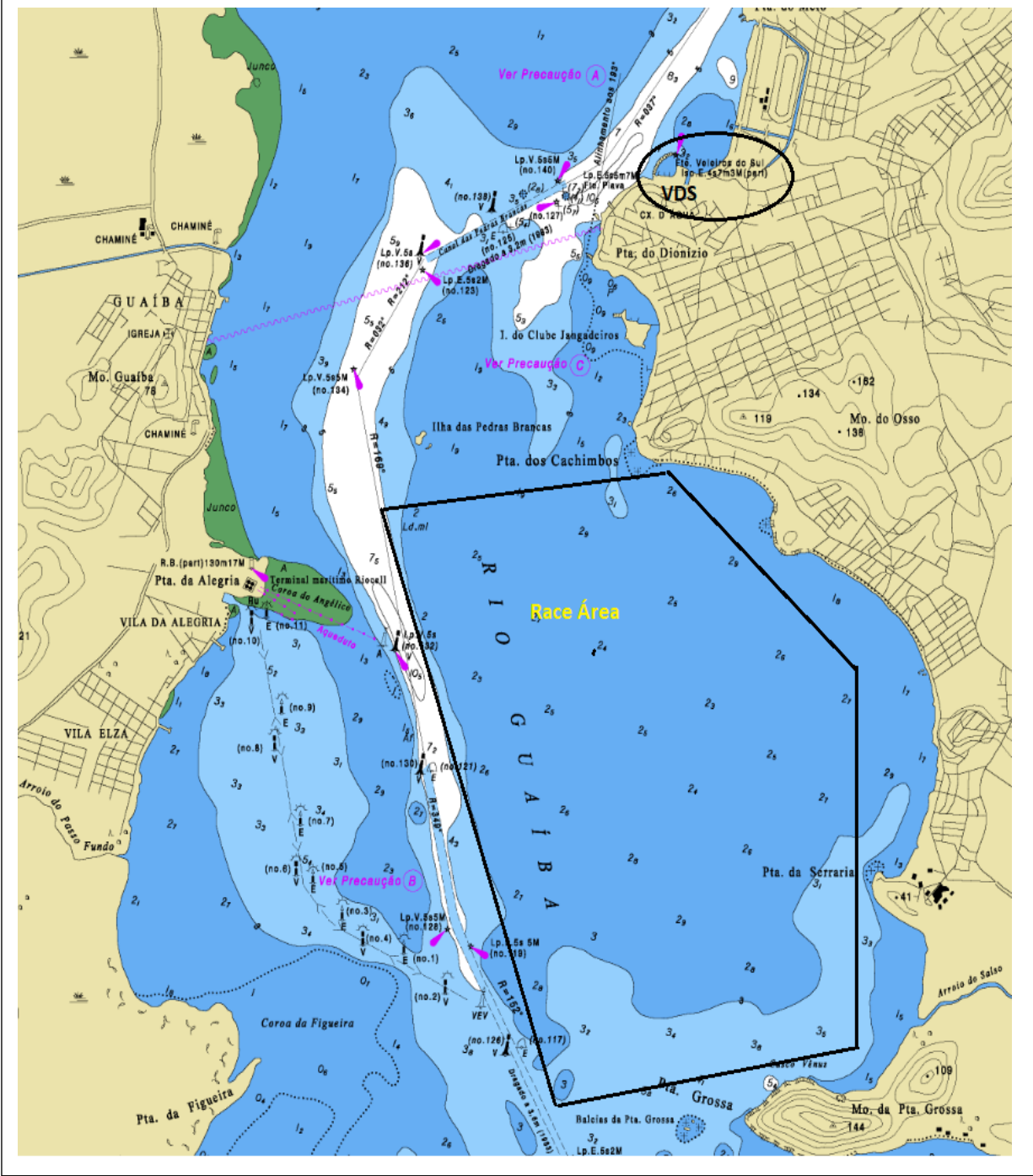

ATTACHMENT B

COURSES

Windward-Leeward, Finish Downwind

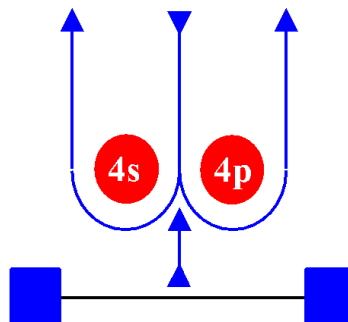
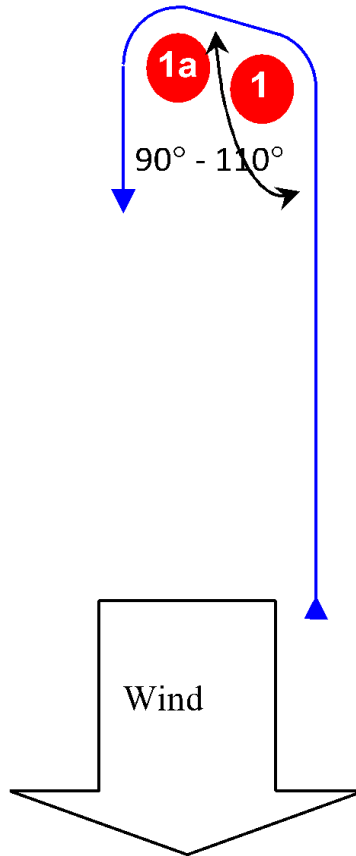

Start - 1 - 1a - 4s/4p - 1 - 1a - Finish

ATTACHMENT C

RRS APPENDIX P, Special Procedures for Rule 42 is replaced in its entirety with:

P1 OBSERVERS AND PROCEDURE

A member of the International Jury, protest committee, or its designated observer (collectively, the “observer”) who sees a boat breaking RRS 42 (Propulsion), RRS 49 (Crew Position; Lifelines), J/70 Class Rule (J70CR) C3.3 (Crew Positioning) or J70CR C9.4(b)(1) (Bowsprit Use) may penalize her by, as soon as reasonably possible, making a sound signal, pointing a yellow or red flag at her and hailing her bow or sail number, even if she is no longer *racing*. A boat so penalized shall not be penalized a second time under rule 42 for the same incident.

P2 PENALTIES

When a boat is penalized under rule P1, her penalty shall be a One-Turn Penalty under RRS 44.2. If she fails to take it, she shall be disqualified without a hearing. If an observer signals a penalty after a boat has finished, her penalty shall be a ten percent (10%) scoring penalty calculated per RRS 44.3(c).

P3 POSTPONEMENT OR GENERAL RECALL

If a boat has been penalized under rule P1 and the race committee signals a postponement or general recall, the penalty is cancelled.

P4 REDRESS LIMITATION

A boat shall not be given redress for an action by an observer under rule P1 unless the action was improper due to a failure to take into account a race committee signal or a class rule.

ATTACHMENT D

J/70 EQUIPMENT REGULATIONS Appendix A: Bow Number Positioning

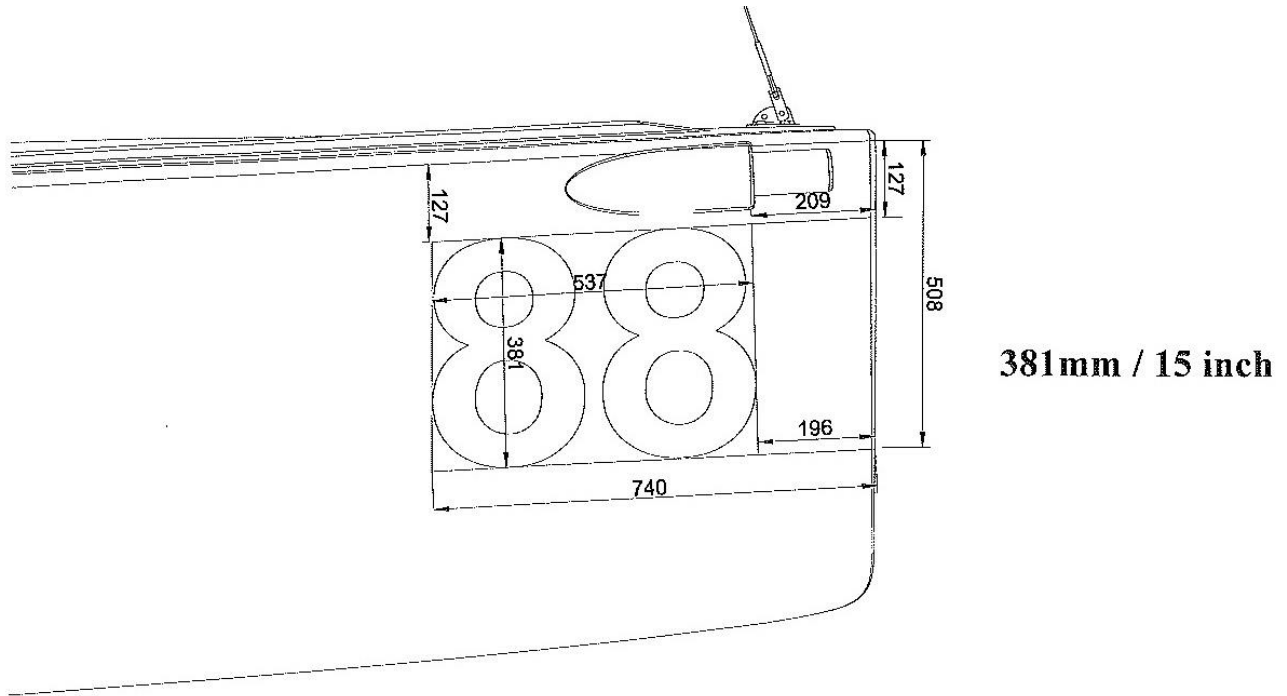

J/70 Class Bow Number Location & Size #1

Standard number - height = 381mm (15")

Dimensions in mm

6-11-2018

ATTACHMENT E

Official Regatta *WhatsApp* Group



N.Board J70 SudAm 2022

Grupo do WhatsApp

